

Duplex filter with segment change over

RE 51408/02.09
Replaces: 08.08

1/18

Types 40 FLDN 0160 to 1001; 40 FLD 0045 to 0274

Nominal sizes **according to DIN 24550**: 0160 to 1001
Nominal sizes according to BRFs: 0045 to 0274
Nominal pressures 40 bar
Connections up to DN 100
Operating temperature -10 °C to +100 °C

Table of contents

Contents	Page
Application, features	1
Design, filter element, accessories, characteristic curves, quality and standardization	2
Ordering details	3
Preferred types	4, 5
Ordering details: Electronic switching element for clogging indicator	6
Plug-in connectors	6
Symbols	7
Technical data	8
Characteristic curves	9...13
Unit dimensions, Spare parts	14...17
Installation, Commissioning, Maintenance	18

Application

- Filtration of pressure fluids and lubricants.
- Direct installation into pipelines.
- Direct wear protection of downstream components and systems.

Features

- Filters for inline installation
- Extremely large filter area
- Low pressure drop
- Special highly efficient filter media
- Versatile applications

Design

The duplex filter consists of two or more filter - housings that are connected by means of tube sockets via a switch housing with segment change over.

Materials: as per spare parts list.

Further design variants available on request.

Filter element

Pleated design with optimized pleat density and various filter media.

The filter element is the most important component of the "FILTER" system in view of the prolonged life and the wear protection of the systems.

The most important criteria for selection are the required degree of cleanliness of the operating medium, the initial pressure differential and the contamination retention capacity.

For further detailed information please refer to our brochure "Filter Elements".

Accessories

Clogging indicator

Basically, the filter is equipped with mechanical optical clogging indicator. The electronic clogging indicator is connected via the electronic switching element with 1 or 2 switching points, which has to be ordered separately. The electronic switching element is attached to the mechanical optical clogging indicator and held by means of a locking ring.

Bypass valve

To protect the filter element during startup and over pressurization due to clogging.

Characteristic curves

An optimum filter selection is made possible by our "BRFilterSelect" software, see download area <http://www.eppensteiner.de>.

Additional characteristic curves for the filters in this catalogue can be found in the BRFS filter calculation program.

Quality and standardization

The development, manufacture, and assembly of BRFS industrial filters and BRFS filter elements is carried out within the framework of a certified quality management system in accordance with ISO 9001:2000.

The pressure filters for hydraulic applications according to RE 51408 are pressure holding equipment according to article 1, section 2.1.4 of the pressure equipment directive 97/23/EC (DGRL). However, on the basis of the exception in article 1, section 3.6 of the DGRL, hydraulic filters are exempt from the DGRL if they are not classified higher than category I (guideline 1/19). They do not receive a CE mark.

Preferred types

Duplex filter with bypass, filtration rating 10 µm and nominal pressure 40 bar

Type	Flow in L/min at 30 mm/s and $\Delta p = 0.8$ bar	Material number
40 FLDN 0160 H10XL-A00-07V2,2-S0M0A	290	R928000395
40 FLDN 0250 H10XL-A00-07V2,2-S0M0A	380	R928000396
40 FLD 0045 H10XL-A00-07V2,2-S0M0A	460	R928000400
40 FLD 0055 H10XL-A00-07V2,2-S0M0A	510	R928000401
40 FLDN 0400 H10XL-A00-07V2,2-S0M0A	710	R928000397
40 FLDN 0630 H10XL-A00-07V2,2-S0M0A	830	R928000398
40 FLD 0120 H10XL-A00-07V2,2-S0M0A	950	R928000402
40 FLDN 1001 H10XL-A00-07V2,2-S0M0A	850	R928000399
40 FLD 0201 H10XL-A00-07V2,2-S0M0A	1500	R928000403
40 FLD 0271 H10XL-A00-07V2,2-S0M0A	1570	R928000404
40 FLD 0272 H10XL-A00-07V2,2-S0M0A	1690	R928000446
40 FLD 0273 H10XL-A00-07V2,2-S0M0A	1750	R928000452
40 FLD 0274 H10XL-A00-07V2,2-S0M0A	1800	R928000458

Duplex filter with bypass, filtration rating 3 µm and nominal pressure 40 bar

Type	Flow in L/min at 30 mm/s and $\Delta p = 0.8$ bar	Material number
40 FLDN 0160 H3XL-A00-07V2,2-S0M0A	130	R928000385
40 FLDN 0250 H3XL-A00-07V2,2-S0M0A	198	R928000386
40 FLD 0045 H3XL-A00-07V2,2-S0M0A	285	R928000390
40 FLD 0055 H3XL-A00-07V2,2-S0M0A	352	R928000391
40 FLDN 0400 H3XL-A00-07V2,2-S0M0A	355	R928000387
40 FLDN 0630 H3XL-A00-07V2,2-S0M0A	515	R928000388
40 FLD 0120 H3XL-A00-07V2,2-S0M0A	735	R928000392
40 FLDN 1001 H3XL-A00-07V2,2-S0M0A	550	R928000389
40 FLD 0201 H3XL-A00-07V2,2-S0M0A	1040	R928000393
40 FLD 0271 H3XL-A00-07V2,2-S0M0A	1190	R928000394
40 FLD 0272 H3XL-A00-07V2,2-S0M0A	1480	R928000445
40 FLD 0273 H3XL-A00-07V2,2-S0M0A	1600	R928000451
40 FLD 0274 H3XL-A00-07V2,2-S0M0A	1650	R928000457

Preferred types

Duplex filter without bypass, filtration rating 10 µm and nominal pressure 40 bar

Type	Flow in L/min at 30 mm/s and $\Delta p = 0.8$ bar	Material number
40 FLDN 0160 H10XL-A00-00V2,2-S0M0A	290	R928020178
40 FLDN 0250 H10XL-A00-00V2,2-S0M0A	380	R928020179
40 FLD 0045 H10XL-A00-00V2,2-S0M0A	460	R928020183
40 FLD 0055 H10XL-A00-00V2,2-S0M0A	510	R928020184
40 FLDN 0400 H10XL-A00-00V2,2-S0M0A	710	R928020180
40 FLDN 0630 H10XL-A00-00V2,2-S0M0A	830	R928020181
40 FLD 0120 H10XL-A00-00V2,2-S0M0A	950	R928020185
40 FLDN 1001 H10XL-A00-00V2,2-S0M0A	850	R928020182
40 FLD 0201 H10XL-A00-00V2,2-S0M0A	1500	R928020186
40 FLD 0271 H10XL-A00-00V2,2-S0M0A	1570	R928020187
40 FLD 0272 H10XL-A00-00V2,2-S0M0A	1690	R928020229
40 FLD 0273 H10XL-A00-00V2,2-S0M0A	1750	R928020235
40 FLD 0274 H10XL-A00-00V2,2-S0M0A	1800	R928020241

Duplex filter without bypass, filtration rating 3 µm and nominal pressure 40 bar

Type	Flow in L/min at 30 mm/s and $\Delta p = 0.8$ bar	Material number
40 FLDN 0160 H3XL-A00-00V2,2-S0M0A	130	R928020168
40 FLDN 0250 H3XL-A00-00V2,2-S0M0A	198	R928020169
40 FLD 0045 H3XL-A00-00V2,2-S0M0A	285	R928020173
40 FLD 0055 H3XL-A00-00V2,2-S0M0A	352	R928020174
40 FLDN 0400 H3XL-A00-00V2,2-S0M0A	355	R928020170
40 FLDN 0630 H3XL-A00-00V2,2-S0M0A	515	R928020171
40 FLD 0120 H3XL-A00-00V2,2-S0M0A	735	R928020175
40 FLDN 1001 H3XL-A00-00V2,2-S0M0A	550	R928020172
40 FLD 0201 H3XL-A00-00V2,2-S0M0A	1040	R928020176
40 FLD 0271 H3XL-A00-00V2,2-S0M0A	1190	R928020177
40 FLD 0272 H3XL-A00-00V2,2-S0M0A	1480	R928020228
40 FLD 0273 H3XL-A00-00V2,2-S0M0A	1600	R928020234
40 FLD 0274 H3XL-A00-00V2,2-S0M0A	1650	R928020240

Ordering details: electronic switching element for clogging indicator

ABZ	F	V	-1X/	-DIN
Rexroth power unit accessories	Filter	Clogging indicator	electronic switching element with 1 switching point (changeover) round plug-in connection M12x1 = E1SP-M12X1	Identification for DIN and SAE models -DIN = Unit series unit series 10 to 19 (10 to 19; unchanged) installation and connection dimensions
			electronic switching element with 2 switching points (normally open/normally closed), 75%, 100%, round plug-in connection M12x1, 3 LED = E2SP-M12X1	1X =
			electronic switching element with 2 switching points (normally open/normally closed), 75%, 100%, signal suppression until 30 °C round plug-in connection M12x1, 3 LED = E2SPSU-M12X1	

Electronic switching element	Material no.
ABZFV-E1SP-M12X1-1X/-DIN	R901025339
ABZFV-E2SP-M12X1-1X/-DIN	R901025340
ABZFV-E2SPSU-M12X1-1X/-DIN	R901025341

Ordering example: Pressure filter with mechanical optical clogging indicator for $p_{nom.} = 40 \text{ bar}$ [580 psi] with bypass valve, nominal size 0055, with filter element $10 \mu\text{m}$ and electronic switching element M12x1 with 1 switching point for pressure liquid mineral oil HLP according to DIN 51524.

Filter: 40 FLD 0055 H10XL-A00-07V2,2-S0M0A **Material number: R928000401**

Clogging indicator: ABZFV-E1SP-M12X1-1X/-DIN **Material number: R901025339**

Plug-in connectors according to IEC 60947-5-2 (dimensions in mm [inch])

for electronic switching element with round plug-in connection M12 x 1

**Plug-in connector for K24 4-pin, M12 x 1
with screwed connection, cable fitting Pg9.**

Material no. R900031155

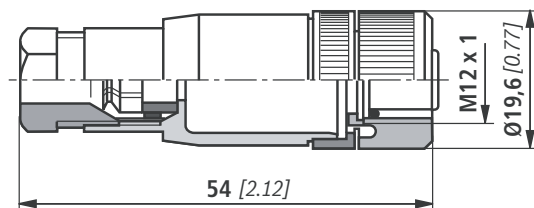

**Plug-in connector for K24-3m 4-pin, M12 x 1
with molded in PVC cable, 3 m long.**

Line cross-section: 4 x 0.34 mm²

Core marking:

1	brown
2	white
3	blue
4	black

Material no. R900064381

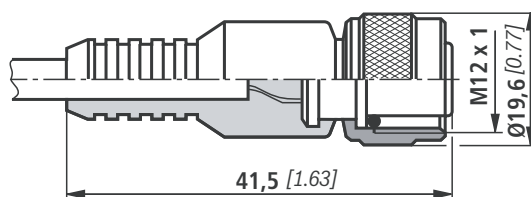

For additional round plug-in connections, see data sheet RE 08006.

Symbols

Pressure filter with bypass and mechanical display

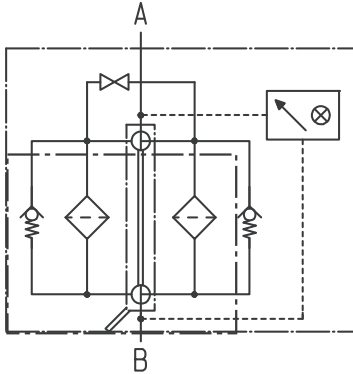

Pressure filter without bypass and mechanical display

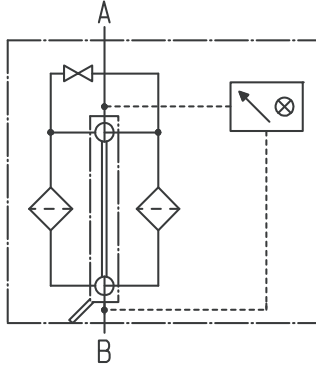

Electronic switching element for clogging indicator

Switching element Plug

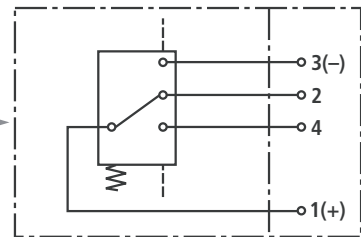

ABZFV-E1SP-M12X1-1X/-DIN

Switching element Plug

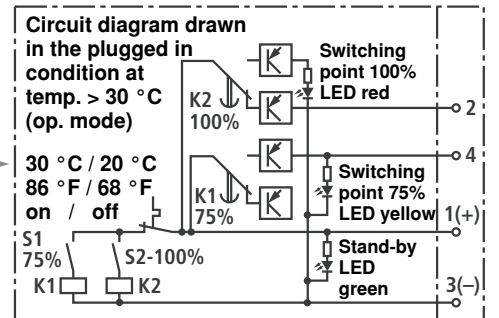

ABZFV-E2SPSU-M12X1-1X/-DIN

Switching element Plug

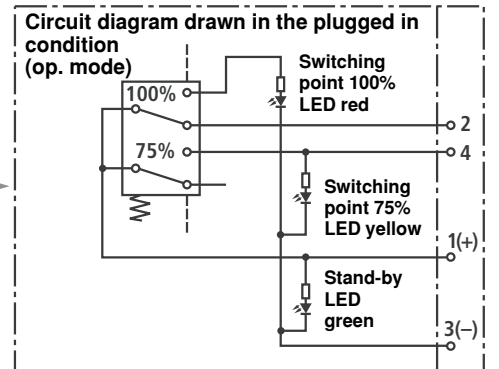

ABZFV-E2SP-M12X1-1X/-DIN

Technical data (for applications outside these parameters, please consult us!)**Electronic** (electric switching element)

Electrical connection		Round plug-in connection M12 x 1, 4-pin
Contact load, direct voltage	A	Max. 1
Voltage range	E1SP-M12x1 V DC/AC	Max. 150
	E2SP V DC	10 to 30
Max. switching capacity with ohmic loads		20 VA; 20 W; (70 VA)
Switching type	E1SP-M12x1	Changeover
	E2SP-M12x1	Normally open at 75% of the response pressure, Normally closed at 100% of the response pressure
	E2SPSU-M12x1	Normally open at 75% of the response pressure, Normally closed at 100% of the response pressure Signal switching through at 30 °C [86 °F], Return switching at 20 °C [68 °F]
Display via LEDs in the electronic switching element E2SP...		Stand-by (LED green); 75% switching point (LED yellow) 100% switching point (LED red)
Type of protection according to EN 60529		IP 65
For direct voltage above 24 V a spark suppression is to be provided to protect the switching contacts.		
Weight electronic switching element: – with round plug-in connection M12 x 1	kg [lbs]	0.1 [0.22]

Characteristic curves

H3XL...

Specific weight: $< 0.9 \text{ kg/dm}^3$

Δp -Q characteristic curves for complete filters recommended
initial Δp for design = 0.8 bar

An optimum filter selection is made possible by our computer program "BRFilterSelect".

Oil viscosity:
 — 120 mm^2/s
 - · - 46 mm^2/s
 - - - 30 mm^2/s

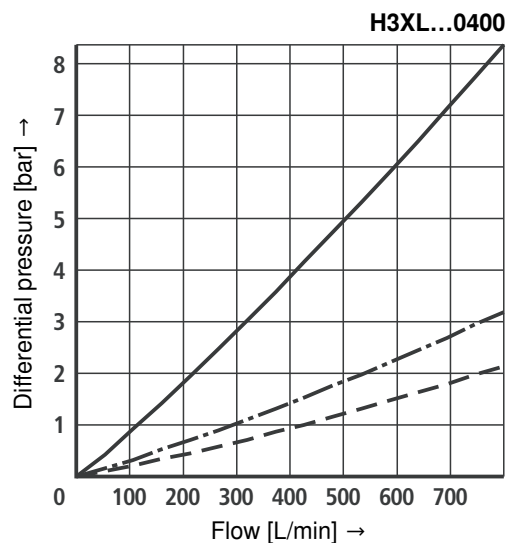
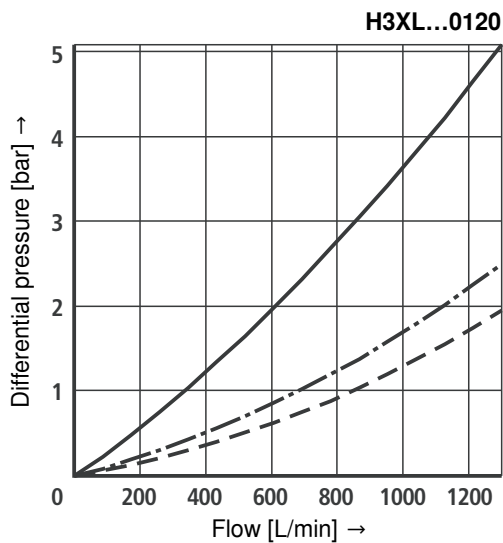
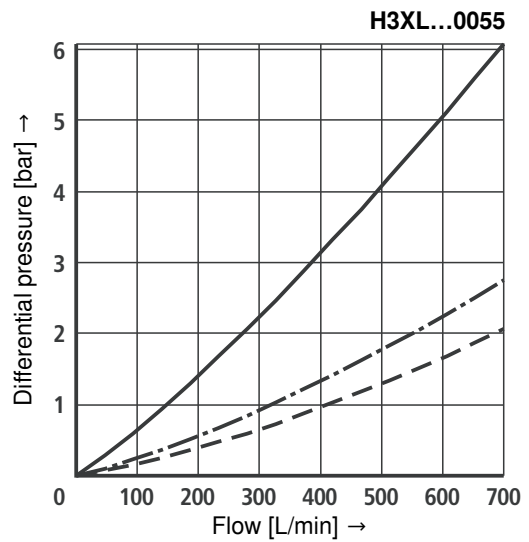
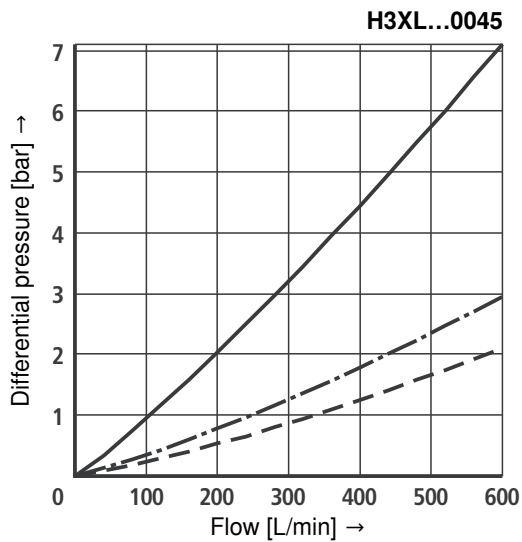
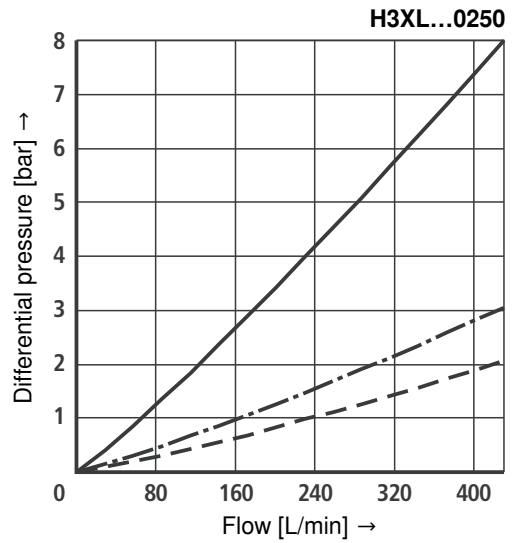
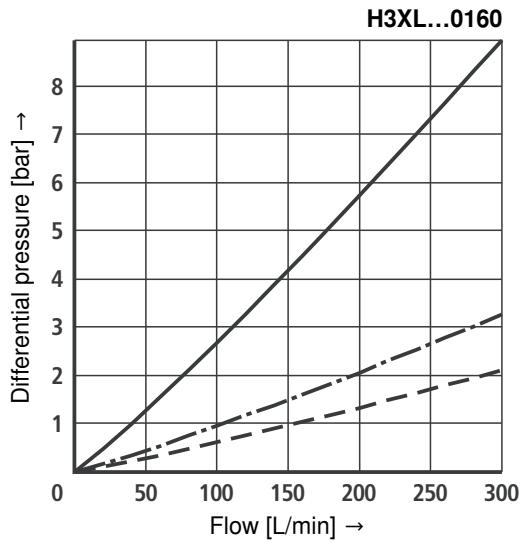

Characteristic curves

H3XL...

Specific weight: $< 0.9 \text{ kg/dm}^3$
 Δp -Q characteristic curves for complete filters recommended
 initial Δp for design = 0.8 bar

An optimum filter selection is made possible by our computer program "BRFilterSelect".

Oil viscosity:
 ——— 120 mm²/s
 - - - 46 mm²/s
 - - - 30 mm²/s

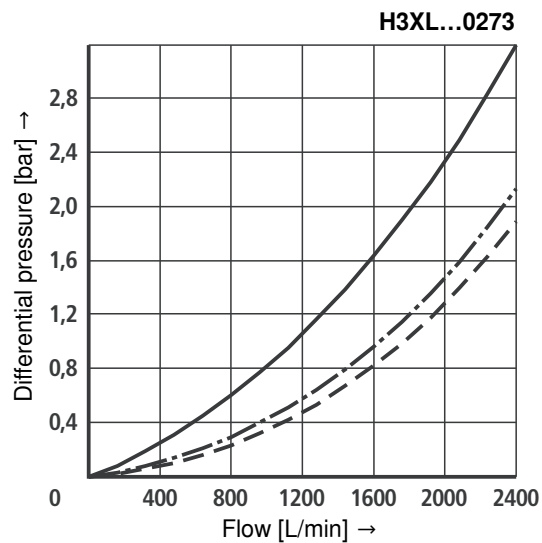
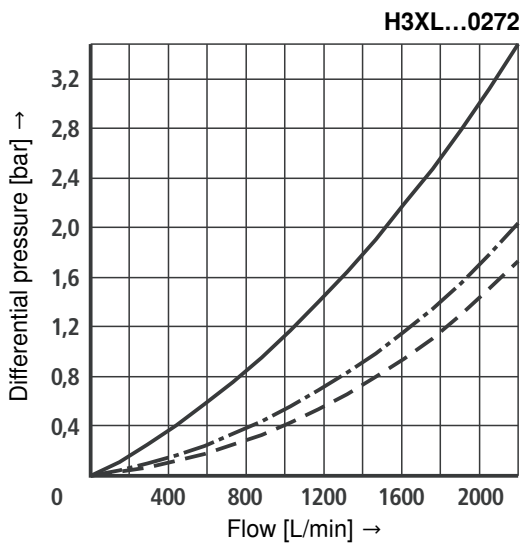
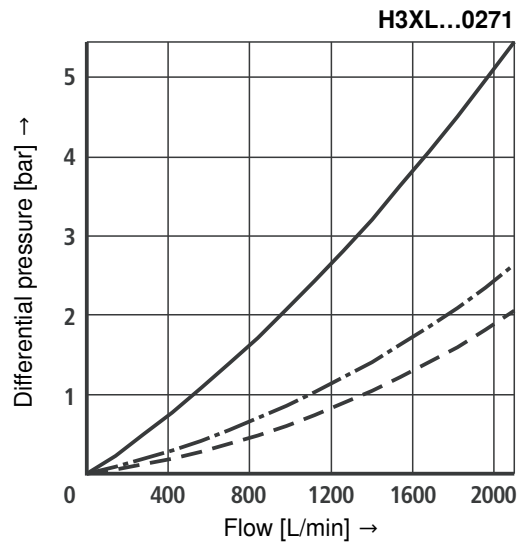
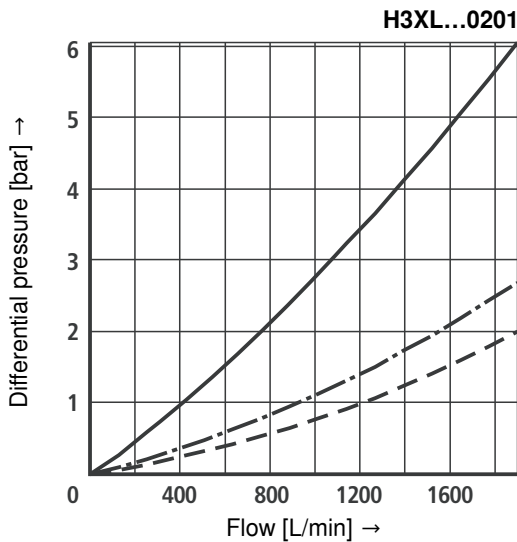
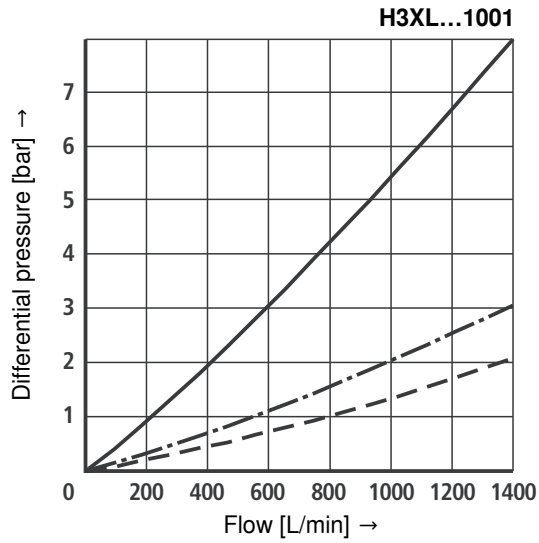
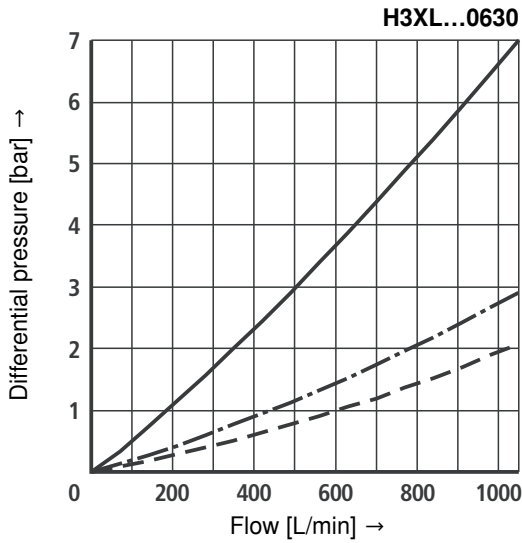

Characteristic curves

Specific weight: < 0.9 kg/dm³
 Δp -Q characteristic curves for complete filters recommended
 initial Δp for design = 0.8 bar

H3XL... and H10XL...

An optimum filter selection is made possible by our computer program "BRFilterSelect".

Oil viscosity:
 ——— 120 mm²/s
 - · - · 46 mm²/s
 - - - 30 mm²/s

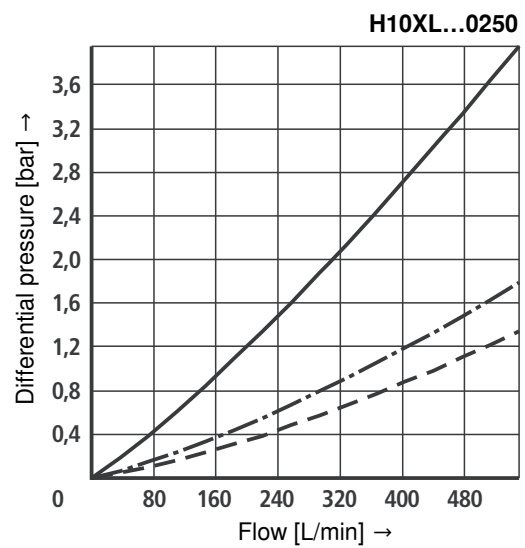
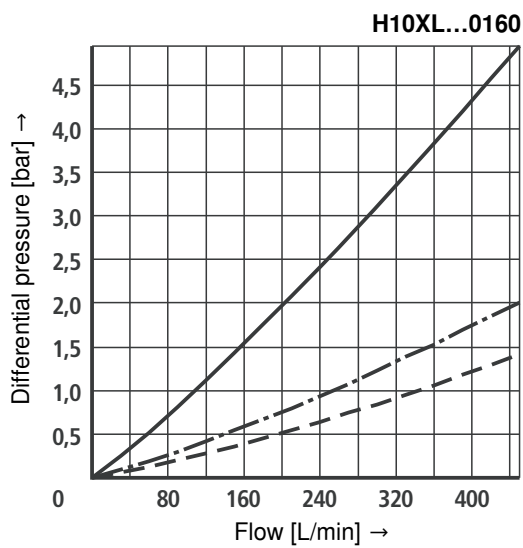
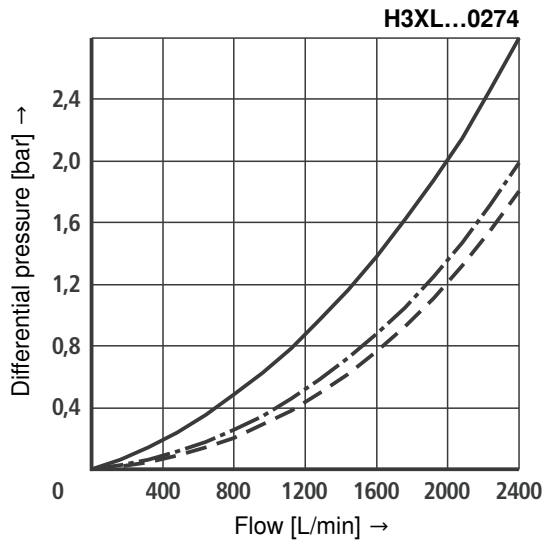

Characteristic curves

H10XL...

Specific weight: $< 0.9 \text{ kg/dm}^3$
 Δp -Q characteristic curves for complete filters recommended
 initial Δp for design = 0.8 bar

An optimum filter selection is made possible by our computer
 program "BRFilterSelect".

Oil viscosity:
 ——— 120 mm^2/s
 - - - 46 mm^2/s
 - - - 30 mm^2/s

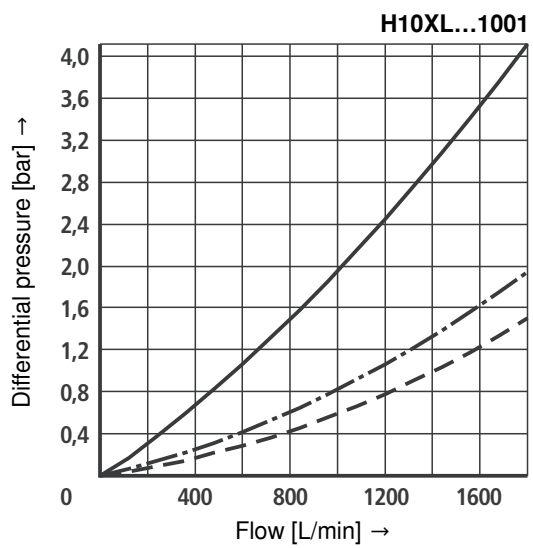
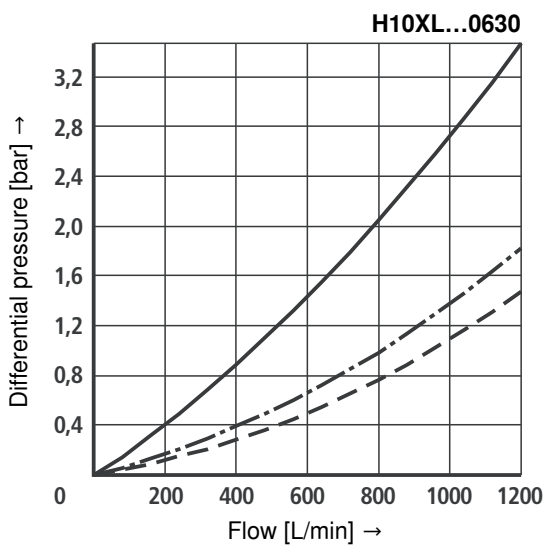
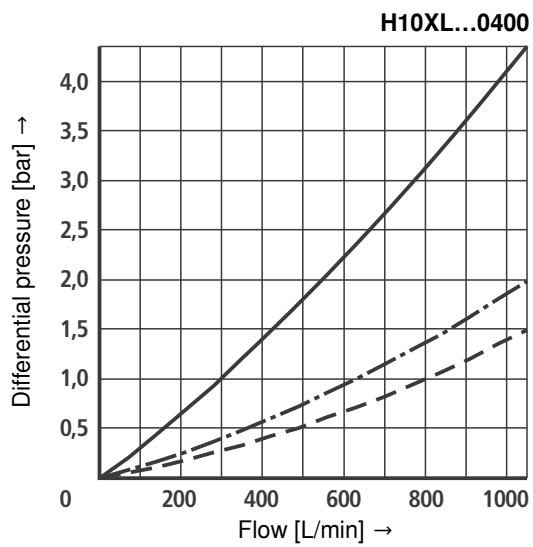
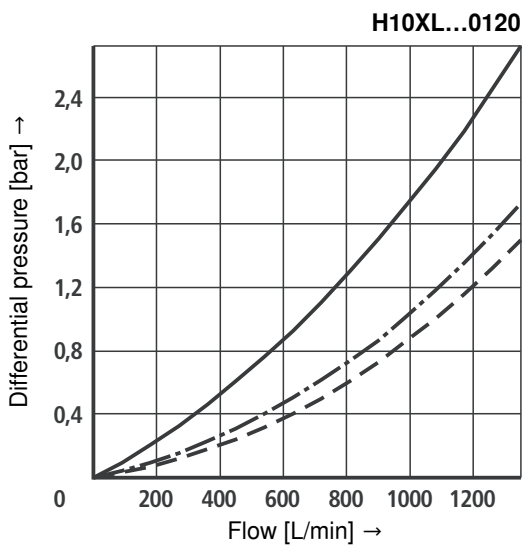
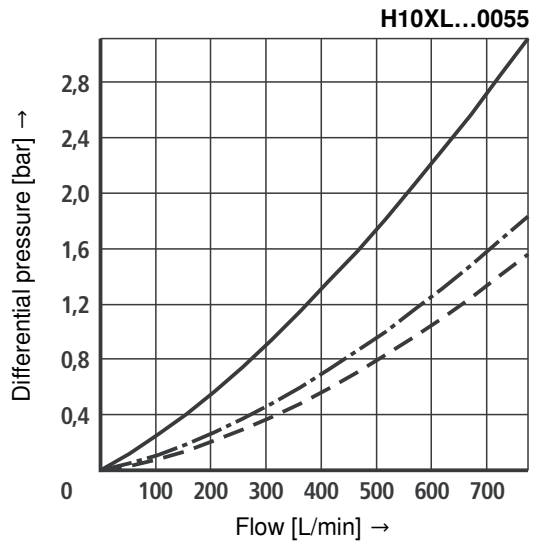
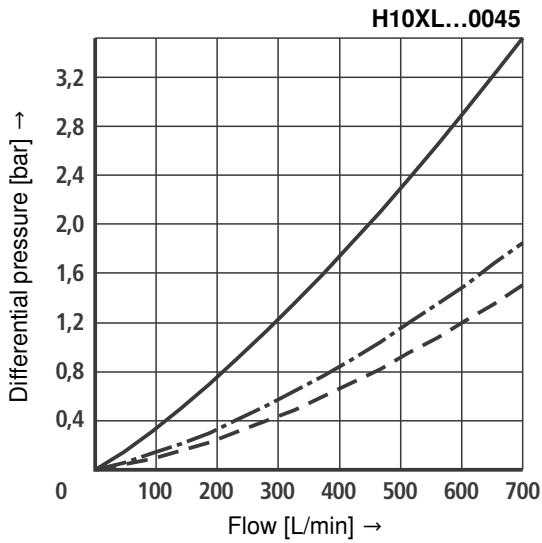

Characteristic curves

H10XL...

Specific weight: $< 0.9 \text{ kg/dm}^3$
 Δp -Q characteristic curves for complete filters recommended
 initial Δp for design = 0.8 bar

An optimum filter selection is made possible by our computer
 program "BRFilterSelect".

Oil viscosity:
 ——— 120 mm²/s
 - - - 46 mm²/s
 - - - 30 mm²/s

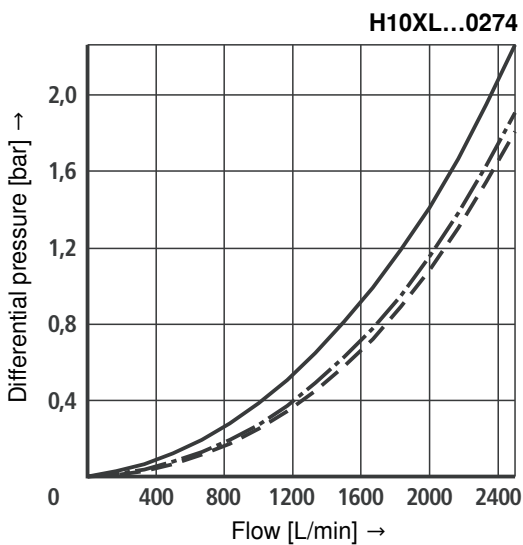
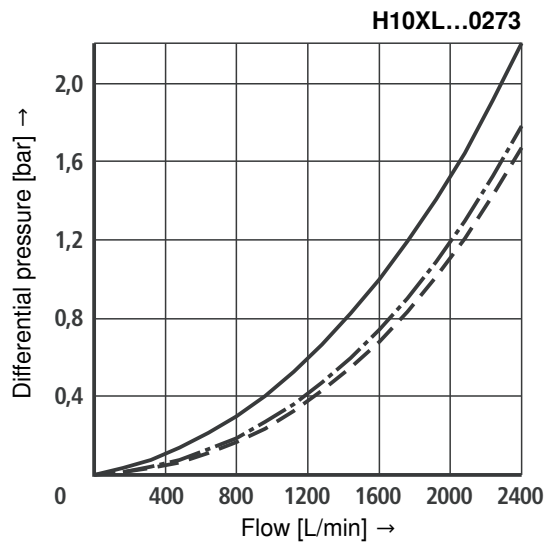
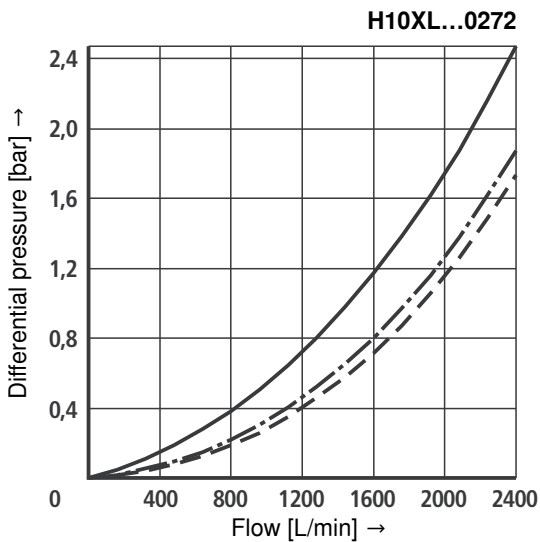
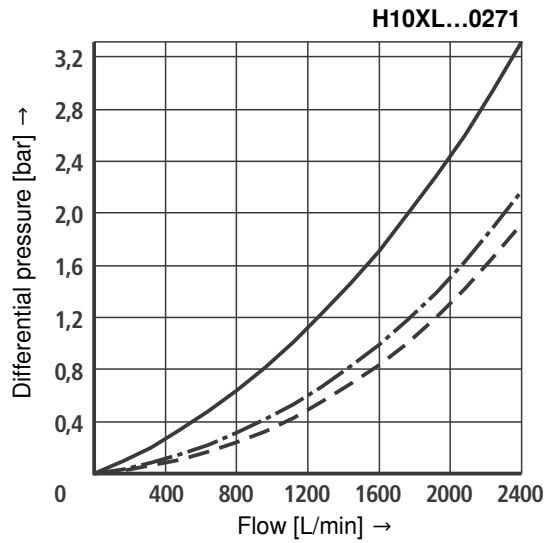
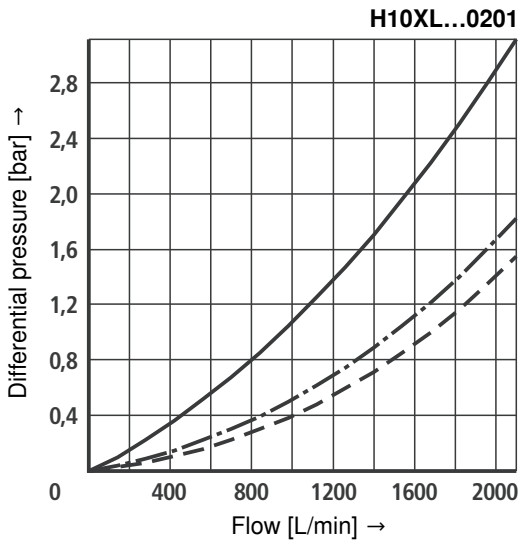

Unit dimensions, spare parts: Types 40 FLDN 0400 - 0630, types 40 FLD 0120 (dimensions in mm)

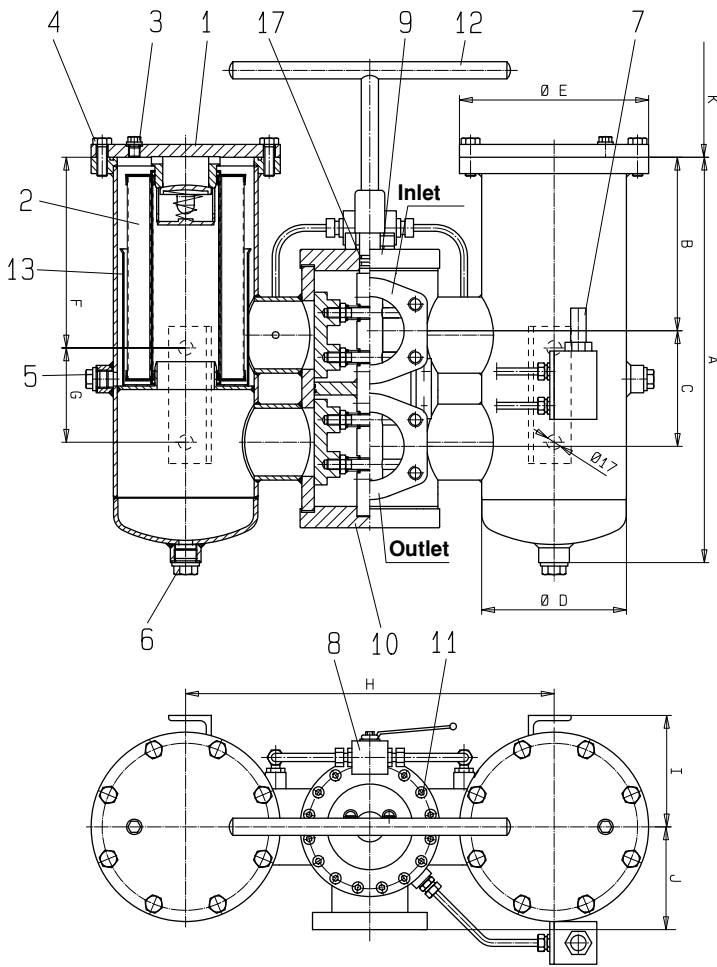

Type	40 FLDN 0160	40 FLDN 0250	40 FLDN 0400	40 FLDN 0630	40 FLD 0045	40 FLD 0055	40 FLD 0120
Volume in L	2 x 4	2 x 5	2 x 8	2 x 11	2 x 6.6	2 x 8.6	2 x 18
Weight in kg			84	86			99
Connection SAE 3000 psi	2"	2"	3"	3"	2"	2"	3"
A	331	421	471	621	571	739	978
B	118	208	200	350	358	526	707
C	105	105	135	135	105	105	135
D	133	133	168.3	168.3	133	133	168.3
E	180	180	220	220	180	180	220
F	108	198	220	370	208	376	587
G	110	110	110	110	250	250	250
H	300	300	430	430	300	300	430
I	111	111	130	130	111	111	130
J	95	95	120	120	95	95	120
K	160	250	250	400	400	570	760

Spare parts

All part numbers BRFS-specific.

Size		FLDN		0160	0250	0045	0055	0400	0630	0120
Part	Piece	Description	Material	Ordering information						
1	2	Filter cover	Steel	Please indicate ordering information Filter						
2	2	Filter element	various	See ordering information Filter Element						
3	2	Bleed screw	Steel	Part No. 4158						
4	12	Hexagonal head screw	8.8	Part No. 596			-			
	16			-			Part No. 595			
5	2	Plug	Steel	Part No. 770			Part No. 789			
6	2	Plug	Steel	Part No. 789			Part No. 790			
7	1	Clogging indicator	various	See ordering information Clogging indicator						
8	1	Pressure compensation valve	various	Please indicate ordering information Filter						
9	1	Switch housing cover	Steel	Please indicate ordering information Filter						
10	1	Switch housing bottom	Steel	Please indicate ordering information Filter						
11	16	Socket head cap screw	8.8	Part No. 637			-			
	32			-			Part No. 639			
12	1	Plug key	Steel	Please indicate ordering information Filter						
13	2	Impact absorber	Steel	Please indicate ordering information Filter						
	1	Sealing kit	various	Please indicate ordering information Filter						

Unit dimensions, spare parts: 40 FLDN 1001, 40 FLD 0201, 0271 (dimensions in mm)

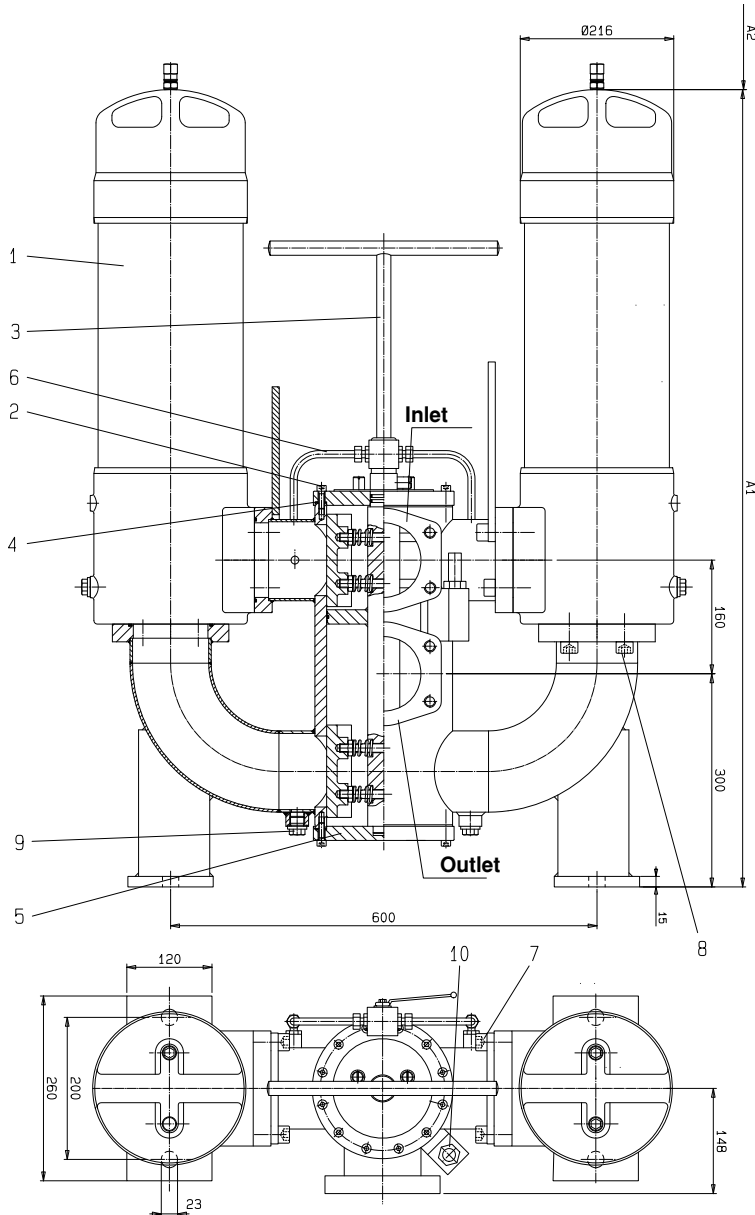

Filter housing for filter element according to DIN 24550

Type 40 FLDN...	Volume in L	Weight in kg ¹⁾	A1	A2 ²⁾	Connection SAE 3000 psi
1001	2 x 12	128	930	400	4"

Filter housing for filter elements according to BRFS standard

Type 40 FLD...	Volume in L	Weight in kg ¹⁾	A1	A2 ²⁾	Connection SAE 3000 psi
0201	2 x 22	176	1280	760	4"
0271	2 x 28	198	1522	990	4"

- 1) Weight including standard filter element and maintenance indicator.
- 2) Withdrawal dimension for filter element replacement.

Spare parts

All part numbers BRFS-specific.

Size		FLDN		1001	0201	0271
		FLD		Ordering information		
Part	Piece	Description	Material			
1	2	Line filter	various	See spare parts data sheet RE 51401		
2	24	Socket head cap screw	8.8	Part No. 638		
3	1	Plug key	Steel	Part No. 1260		
4	1	Switch housing cover	Steel	Please indicate ordering information Filter		
5	1	Switch housing bottom	Steel	Please indicate ordering information Filter		
6	1	Pressure compensation line	various	Please indicate ordering information Filter		
7	4	Socket head cap screw	8.8	Part No. 5011		
8	12	Socket head cap screw	8.8	Part No. 661		
9	2	Plug	Steel	Part No. 789		
10	1	Clogging indicator	various	Please indicate ordering information Filter		
	1	Sealing kit	various	Please indicate ordering information Filter		

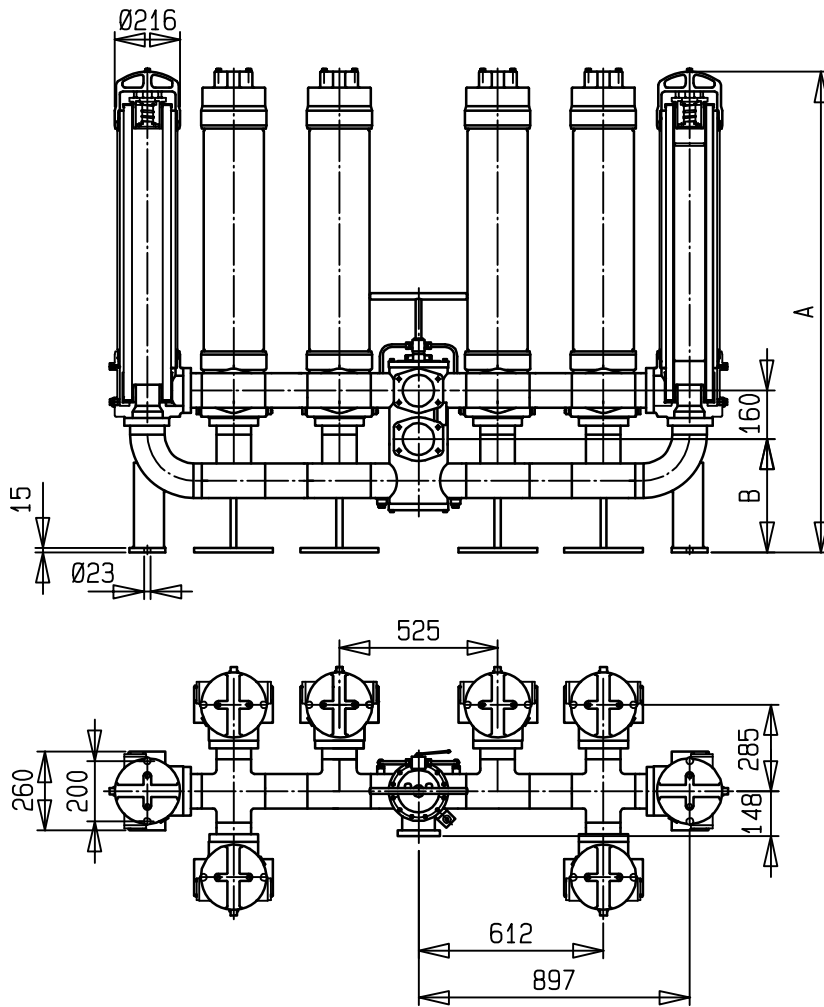
Unit dimensions: type 40 FLDN 1001, types 40 FLD 0201 - 0274 (dimensions in mm)**Filter housing for filter element in accordance with DIN 24550**

Type	Number of filters	Number of filter elements	A	B	Connection SAE 3000 psi
40 FLDN 1001	2 x 1	2 x 1.1000	930	300	4"

Filter housing for filter elements according to BRFS standard

Type	Number of filters	Number of filter elements	A	B	Connection SAE 3000 psi
40 FLD 0201	2 x 1	2 x 1.0200	1280	300	4"
40 FLD 0271	2 x 1	2 x 1.0270	1522		4"
40 FLD 0272	2 x 2	4 x 1.0270	1590	375	DN 100
40 FLD 0273	2 x 3	6 x 1.0270			
40 FLD 0274	2 x 4	8 x 1.0270			

Spare parts (insert for DIN and SAE filters)

Mechanical optical clogging indicator

Rexroth power unit accessories

Filter

Clogging indicator

Mechanical optical clogging indicator for low-pressure filters

Switching point 2.2 bar [32 psi]

= NV2

ABZ F V - NV2 - 1X / - DIN

DIN =

Identification for DIN and SAE models

M =

V =

Sealing material

see table below

see table below

Unit series

unit series 10 to 19

(10 to 19; unchanged

installation and connection dimensions)

1X =

Mechanical optical clogging indicator	Material no.
ABZ FV-NV2-1X/M-DIN	R901025312

The ordering details for filter elements can be found on page 3.

Sealing kits must be ordered by stating the complete part key.

Sealing material and surface coating for pressure fluids

		Ordering details	
		Sealing material	Element model and material
Mineral oils			
Mineral oil	HLP according to DIN 51524	M	...0
Fire-resistant hydraulic fluids			
Emulsions	HFA-E according to DIN 24320	M	...0
Synthetic water solutions	HFA-S according to DIN 24320	M	...D
Water solutions	HFC according to VDMA 24317	M	...D
Phosphate esters	HFD-R according to VDMA 24317	V	...D
Organic esters	HFD-U according to VDMA 24317	V	...D
Hydraulic fluids that are fast biodegradable			
Triglycerides (rape seed oil)	HETG according to VDMA 24568	M	...D
Synthetic esters	HEES according to VDMA 24568	V	...D
Polyglycoles	HEPG according to VDMA 24568	V	...D

Installation, commissioning and maintenance

Installation

Verify operating pressure with name plate information. Install the filter into the pipe work; when doing so, consider the flow direction (direction arrows) and the withdrawal height of the filter elements.

Warning!

Vessel is under pressure!

Assemble and disassemble the filter only when system is de-pressurized!

Keep the pressure compensation closed if the filter is open!

Do not operate the change over valve when the filter is opened!

Do not replace the clogging indicator and the pressure compensation while the filter is under pressure!

Functional and safety warranty only applicable when using genuine Rexroth spare parts!

Service filter only by trained personnel!

Commissioning

Move the switch lever into the central position in order to fill both filter sides. Switch on system pump. Bleed filter by opening the bleed screw, close when operating fluid vents. Switch filter into its operating position. In this connection, the switch lever must be in the stop position.

Maintenance

If at operating temperature, the red indicator pin shows out of the clogging indicator so far that it contacts the plastic cap and/or if the switching process in the electric display is triggered, the filter element is clogged and needs to be replaced or cleaned respectively.

Filter element replacement

Open the pressure compensation line, switch the switch lever over into the opposite direction to the stop to the clean filter side. Close the pressure compensation line again. Open the bleed screw and reduce the pressure. Close the bleed screw again. Disassemble the filter cover. Open the plug and drain the filter; then close the plug again. Remove the filter element from the lower centering spigot in the filter housing by turning it lightly. Check the filter housing for cleanliness and clean if necessary.

Replace filter elements H...-XL, P. The filter element with mater G... is cleanable. The efficiency of the cleaning process depends on the type of contamination and the value of the pressure differential before the filter element was exchanged. If the pressure differential after replacing the filter element is less than 50% of the value of a new filter element, the cleaning is not reasonable any more. Install the cleaned or new filter element into the filter housing. Check the seal ring and replace it in case of damage. Mount the filter cover. Bleed filter by opening the bleed screw, close again when operating fluid vents.

Technical modifications reserved!